



MandiCasa

by Dario Snaidero

ENHANCING LIVES THROUGH DESIGN



KITCHENS SYSTEMS & ACCESSORIES



“MandiCasa means decades of design experience
at your service, from beginning to end.”

—Dario Snaidero, Founder

Kitchen Systems

The perfect balance between functionality and aesthetic design is achieved thanks to a system for producing tall units with retractable doors. These units can be fitted with household appliances, bespoke accessories, and a pull-out stainless-steel top.

Wing

The Wing cabinet with its receding doors reveals surprising versatility with which to create new, perfectly equipped work areas that can be concealed if necessary.

The Wing cabinet features handleless pocket doors that fold out of view to the sides of the unit to reveal a fully equipped storage area or workstation. Elements available to customize the unit include drawers, open shelves, a backlit accessorized panel, counter space, a pull-out stainless steel worktop, and appliances cabinets.

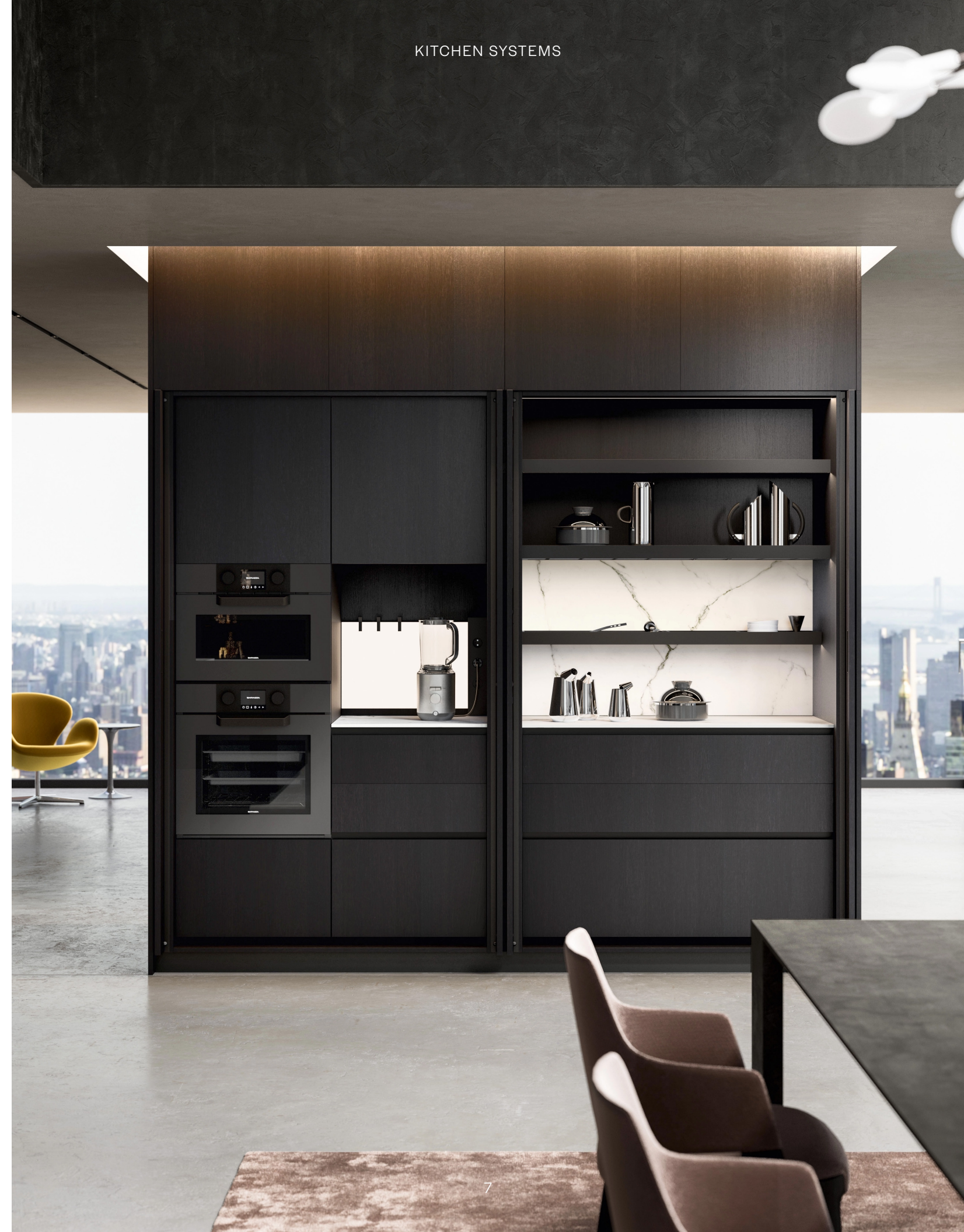



Wing cabinets can be paired together (pictured), with each unit dedicated to specific functions. They can stand alone or integrate within the pantry wall. When the pocket doors are closed, the element becomes a sophisticated furnishing solution that bridges across kitchen and living spaces.

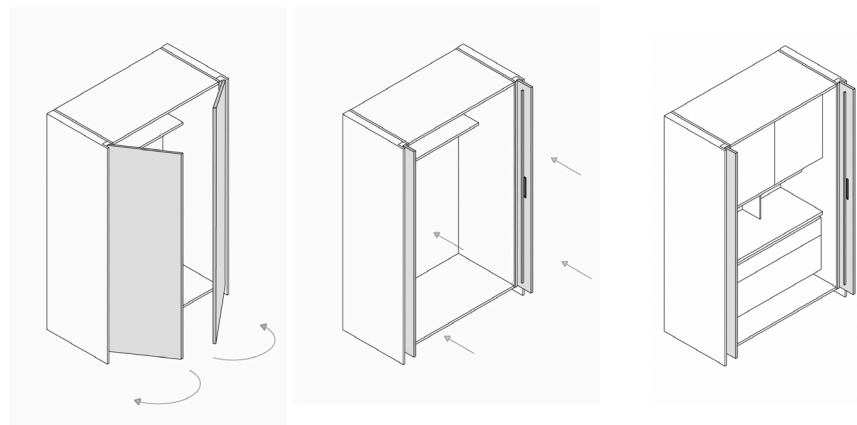

Hide

The Hide system, which can close or reveal entire work areas, combining finesse and technology. With Hide, all the functional areas of the kitchen can remain out of view when not in use. The system expands the Wing concept even further, creating luxury workstations that bring kitchen, dining, and living room together and are ideal for entertaining guests at home.

Every Hide unit comes with bifolding pocket doors and even more space to organize one's needs with appliances, cabinets, open shelves systems, drawers, storage racks, sinks and cooktops. The finishes can match the rest of the kitchen to create effortless visual continuity, while the placement of the lights inside the unit enhances the appeal of the system and the entire design.





In the Hide system, bifolding pocket doors reveal or conceal a fully customizable functional unit inside tall cabinets matching the rest of your MandiCasa kitchen.

Inside, the Hide system can be customized with drawers, deep storage cabinets, open shelves, integrated appliances, and an accessorized storage wall.

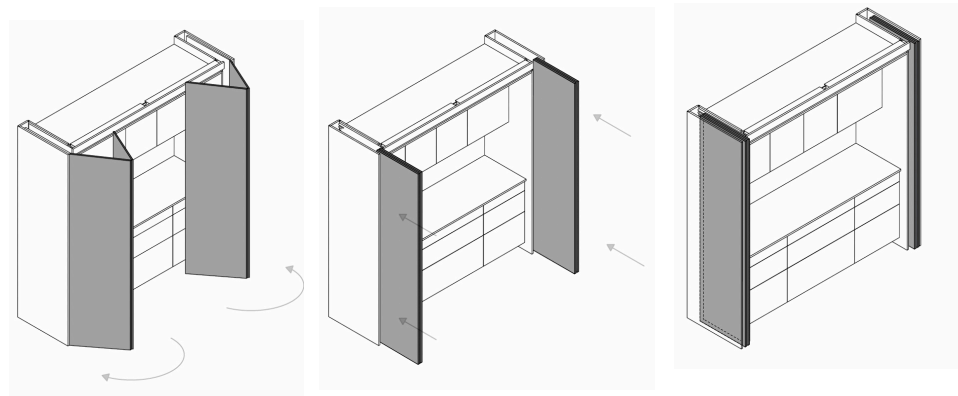

Mover

Introducing the Mover, a sophisticated vertical slider designed for seamless and elegant storage solutions. Unleash the potential of hidden spaces with its sliding panel that effortlessly conceals compartments. Experience the quiet, smooth glide on precision rails, ensuring a fluid and noise-free movement. Elevate your storage experience with Mover's sleek design and functional efficiency.





The Mover system is set against the wall, underneath the upper cabinets. It consists of vertical, downward sliding panels that elegantly hide and reveal extra storage compartments matching the finishes used for the rest of the kitchen.

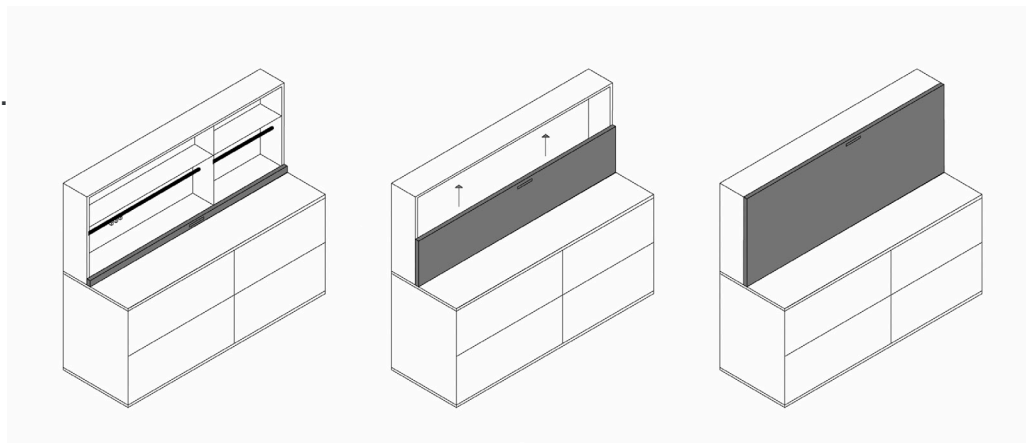

Corner

Corner is a snack counter system made to expand the usable surface of the kitchen island. A recessed sliding mechanism with aluminum tracks allows the counter to slide out diagonally, almost doubling the worktop space, and then retreat onto the island when no longer needed. Corner is available for wood veneered snack counters with 45° edges and straight-edged Fenix laminate tops.





Through the Corner mechanism, the snack top slides out diagonally on hidden aluminum tracks to extend the surface of the island.

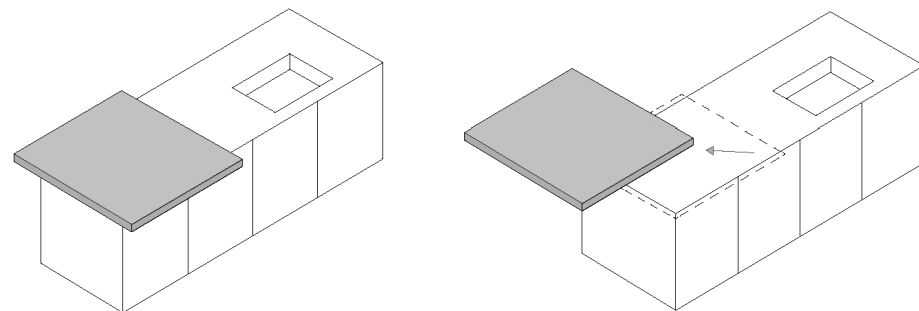



Island snack table in oak wood, sliding in and out diagonally. It can have 45-degree inclined edges on all sides.



Round snack table with 30-degree inclined edge. It can be attached to the end of the island in four different ways. Walnut and oak finishes with leg in black anodized aluminum.

Pivot Doors

Pivot doors give designers great freedom to hide passageways connecting the kitchen to adjacent rooms, wine cellars, wet kitchens, or pantry areas. Available in the same finish as the tall cabinets, the doors maintain the visual continuity of the design.

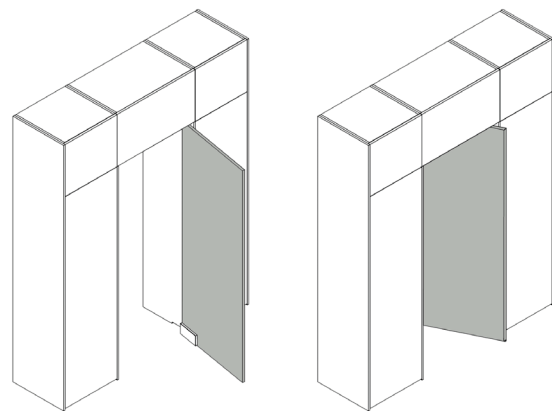



Kitchen Accessories

MandiCasa offers a diverse array of features designed to elevate kitchen performance and inspire innovative ideas for a unique and functional space. Our interior accessories empower creative utilization of all available space, while our kitchen accessories present customization possibilities and streamline every culinary activity.



Infinity

The Infinity boiserie in Noce (Walnut) Caramel melamine features minimalist open shelves in Black anodized aluminum. The same finishes are used on the glass cabinets, creating an elegant display area on the wall that harmonizes the kitchen with the living room.





The Infinity wall boiserie features panels in Noce (Walnut) Cortina melamine (also used on the back of the island) and movable metal shelves.

The infinity system represents an elegant and refined solution to decorate the wall. It is a modular system that through aluminum profiles allows you to use panels of different finishes giving continuity between base units and wall units or even to become a solution in its own right. Aluminum shelves are available that add efficiency to the kitchen by taking advantage of the vertical space behind the work area.

Metal Box

Powder coated sheet metal wall units are available in a choice of two colors and several dimensions. Can be turned to the required position during mounting. The units are made up of electro welded metal sheets, carefully finished before the coating operation, so that they appear to be a single unit.





Metalbox open storage units integrated into upper cabinet, in Black lacquered metal.



Size

Open units in square tube aluminum consisting of a base, a back panel and, on some units, shelves. Made from graphite black anodized aluminum, they can be hung individually on the wall or combined to create a unique composition of wall units.





The Size open units in Graphite Black anodized aluminum consist of a base, a back panel and shelves. Combine individual units on the wall to create a unique composition.



The walnut finish used on the wall unit with framed glass cabinets is mirrored by the kitchen Island.

The open shelves on the island and framed glass cabinets blend the kitchen with the living area.

Frame

A finely crafted aluminum frame meticulously assembled with the glass panel creates an exclusive and refined accessory.

The range of available modules provides glass door solutions for wall, base and tall units.





The new glass doors feature a smoked glass panel set in a black anodized aluminum frame with an integrated pull on one side running along the full height of the door.

Completing the composition are the Frame display cabinets in smoked glass with Black anodized aluminum frame and back panels in Blu Petrol micalized lacquer.



Smoked glass cabinets with Black anodized aluminum frame add an elegant touch to the design.





Modular, essential, and functional, Modus is another storage system for the kitchen wall. Open and closed elements can be arranged freely.

Modus

Exclusive storage accessories that can be freely arranged, crafted entirely from skillfully assembled brush finish aluminum.





Modus 2.0 movable modular storage system works for various countertop locations and adds functionality

KITCHEN ACCESSORIES



Sleek, bold lines create a modern and essential design making them a distinctive feature of the kitchen.



Modular

The under-cabinet solutions available in the Modular range completely redesign the working area, creating a wall storage system for kitchen tools that can be completed with a variety of accessories.

A versatile system enabling everyone to find the perfect combination to interact effectively with their own kitchen.



Under the cabinets, the Modular system includes a variety of accessories for frequently used kitchen tools: glass and aluminum shelves, paper towel holders, jar holders, glassware holders, coffee capsules holders, and hanging rails



Wall units feature a burnished aluminum Modular storage wall that extends usable space in the kitchen.

On the wall is a Modular open storage system in burnished anodized aluminum.



Qanto

Developing kitchen design every inch becomes relevant. “Qanto” provides a brand-new solution for corner base units in matter of retention capability. Two electrically liftable shelves allow to fulfill a user-friendliness working space in the kitchen.





Ideal for corner base cabinets, Qanto consists of two space-saving electrically liftable shelves.



The system blocks the mechanism when it detects the presence of a hand, ensuring safety of use.



Palo

Free assembling, black anodized, aluminum bookshelf. Can be turned into a kitchen equipped wall system, or a free-standing bookshelf.

The Palo open storage system for the kitchen wall presents multiple assembly options with a mix of wood shelves, metal trays, and accessory bars.

We can see it pictured in all its versions where the vertical element allows the choice of multiple assembly positions of wood shelves, metal trays and utility bars.





The Palo open shelving system shown in Black anodized aluminum. The system can be attached to the kitchen wall or built as a free-standing solution.



Sleek, bold lines create a modern and essential design making them a distinctive feature of the kitchen.



Interior Accessories

Cabinet drawers are offered in diverse styles and configurations. When selecting drawers for your kitchen, understanding the available options is beneficial.

Drawers & Baskets

Cabinet drawer accessories are essential elements that contribute to efficient utensil storage, enhancing overall functionality.







Elegant and customizable, the Elite Line drawer organizers come with Oak or Black Walnut inserts and stainless-steel bases.

Easy line kitchen basket for pots and pans with adjustable, magnetic wood pegs.



The Easy Line offers drawer and deep drawer accessories in Beech, Black Walnut, Wenge, or White wood, both modular and non-modular. Bases in stainless steel or matching wood.

Base Units

Base Unit creates spaces that are not only practical but also exude elegance. The full extension guides are equipped with damped retraction, three-dimensional adjustment of the door included. Designed to optimize storage within base units elevating your living spaces with this seamless fusion of practicality and style.



Also available are glass shelves with stainless steel frames that allow the LED light to filter through to every part of the cabinet, for even greater illumination.



Fully extractable storage, fly box baskets for corner base cabinets.

INTERIOR ACCESSORIES



Lazy Susans and storage solutions for corner cabinets. Extractable systems of double trays (top and bottom) with protective railings allow the full utilization of corner cabinets in depth and width.



The vast range of modules in the MandiCasa collection includes several solutions for making the most of the storage space inside corner units.

Equipped Pantry

The perfect balance between functionality and aesthetic design is achieved thanks to a system for producing tall units with retractable doors. These units can be fitted with household appliances, bespoke accessories, and a pull-out stainless-steel top.



Tall Storage Unit

The tall storage units in the MandiCasa collection are equipped with made in Italy systems designed to last in time. They enable all the interior storage space to be easily organized, accessed and used, in keeping with the best ergonomically designed kitchens. These units provide efficient organization, easy access, and optimal utilization of interior storage space. Embrace the epitome of ergonomically designed kitchens with MandiCasa, where functionality seamlessly meets enduring style.





In the columns, the height of the shelves can be adjusted to fit different storage needs.



INTERIOR ACCESSORIES









MandiCasa reserves the right to make changes to this catalog at any time in the interest of improving its products. The reproduction or even partial reproduction of any text, images or designs featured in this catalog is strictly forbidden. All rights reserved. Brands and logos showing on the present catalog are of LUXITALY Group Inc property and the companies that respectively are depicted.



MandiCasa

by Dario Snaidero

877.762.4337 | mandicasa.com
a LUXITALY Group Inc brand